

M830 Angular Display & M425 Proportional Angle Sensor

Data Sheet 114

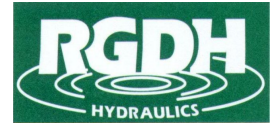

Application:

Where it is required to have proportional remote indication of level attitude, the Model 830 Angular Display can be coupled to the Model "X-Y" Angle Sensor for direct readout of direction and magnitude of tilt.

The Model 830 Angular Display can also be used with a P-Q joystick control to give an indication of operation.

The Model 425 Angle Sensor can also be used with a P-Q valve drive board for automatic proportional re-leveling of one axis or both axes.

Features:

Model 425 is an inductively coupled pendulous level sensor which can provide a voltage proportional to degree of tilt for both its major axes. The maximum angle is $\pm 6^\circ$ from true level.

There are only four wires necessary for connecting the M425: Power, Ground, and "X" and "Y" Outputs. The Model 425 is viscously damped and minimizes flutter of output when the sensor is mounted on a vibrating machine.

Model 830 is an angular display which accepts DC supply power from a 10-30 VDC source, a built-in regulator keeps the supply power to its electronics and the output power to the sensor at a constant voltage.

The Model 830 comes with a bar display. In each quadrant the LED's will light and stay lit in proportion to angular tilt.



A power-on light in the center of the display indicates when the angular readout is ready for operation. A power-on switch can be provided which gives either a momentary (60 seconds) or continuous "on" power. The momentary switch is particularly useful when using a battery supply, keeping discharge to a minimum. When powered from a continuously available power supply, the switch would not be necessary.

Other available models:

For level sensing, see Data Sheets 106 and 107 which describe the Model 400 Omni-directional and Model 420 Di-axial Level Sensors.

For platform leveling, see Data Sheet 108 which describes the Model 410 Automatic Platform Leveler.

Specifications:

Model 425 Angle Sensor:

Supply Voltage: 6VDC

Full Signal: $\pm 6^\circ$ (adjustable gain)

Current at 6 VDC: 20 mADC

Output range: 3 VDC neutral, ± 1.8 VDC swing

Operating Temperature: -40° C to $+70^\circ$ C

Hysteresis: 0.3°

Model 830 Angular Display:

Supply Voltage: 10 to 30 VDC

Current at 12 VDC: 175 mADC Centered

230 mADC One Bar Full-on

290 mADC Two Bars Full-on

Operating Temperature: -40° C to $+85^\circ$ C

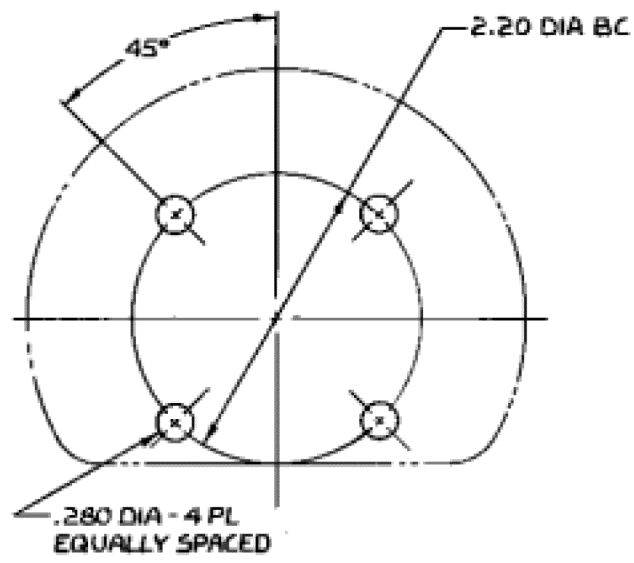
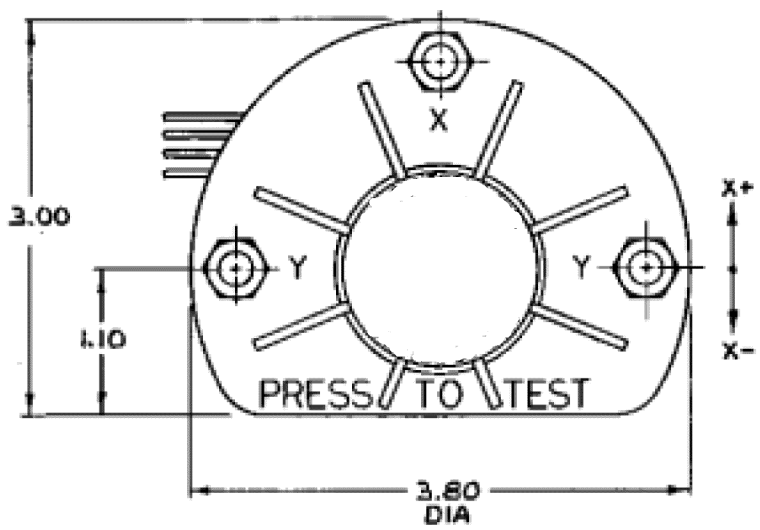

MOUNTING HOLE PATTERN IN BASE PLATE. STEEL PLATE ALSO SUITABLE FOR WELDING TO MACHINE.

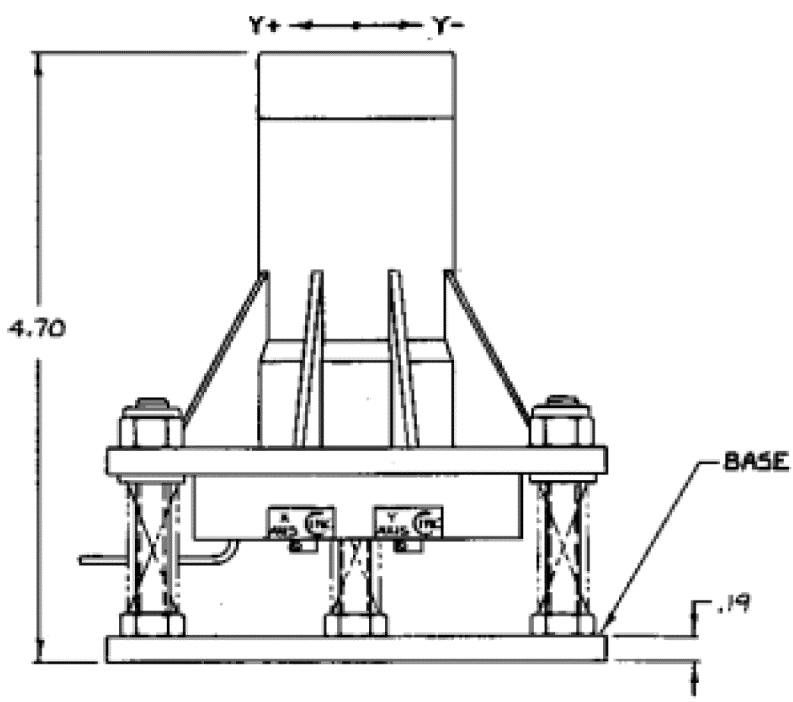

REV.	DESCRIPTION	DATE
A	GREEN WIRE WAS BROWN BLUE WIRE WAS GREEN	3-31-83 RAS
B	X OUTPUT WAS YELLOW Y OUTPUT WAS BLUE	6-13-83 RBS
C	ADDED 10% OUTPUT AT 6°	3-12-84 RBS
D	REMOVED Y&F OUTPUT	4-30-84 RBS

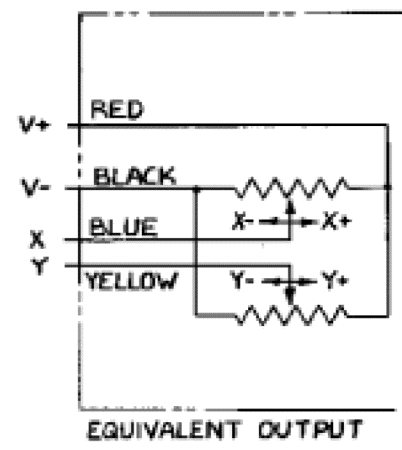

- 3) X&Y OUTPUTS ARE EQUAL TO 50% OF V+ AT LEVEL, 60% OF V+ AT +6° INCLINATION & 40% OF V+ AT -6° INCLINATION PROPORTIONAL WITH INCLINATION ANGLE.
- 2) MAXIMUM INCLINATION ANGLE IS 7°

NOTES: 1) V+ CAN BE 6 OR 12 VDC

		DRAWING NO.		REV.
		SIZE	SCALE	
MATERIAL SPEC.		DRAWING TITLE		
COND.		DI-AXIAL ANGLE SENSING TRANSDUCER		
SURF. TREAT.		MODEL 425 - 30		
OPTIM.	CHECK	PROJ. ENGR.	DATE	
			2-28-83	

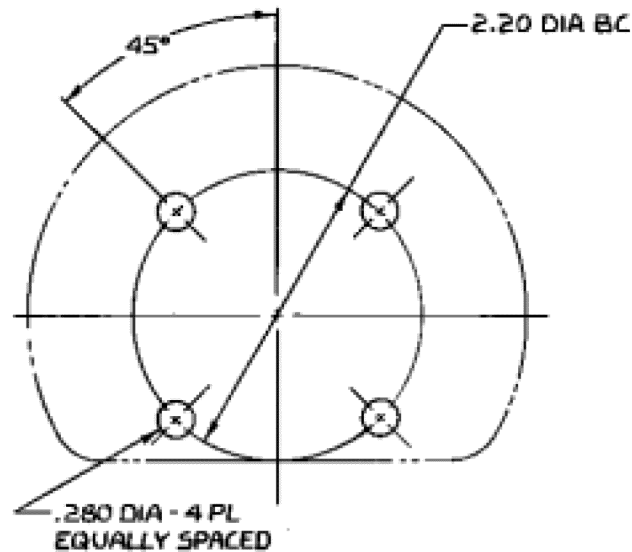
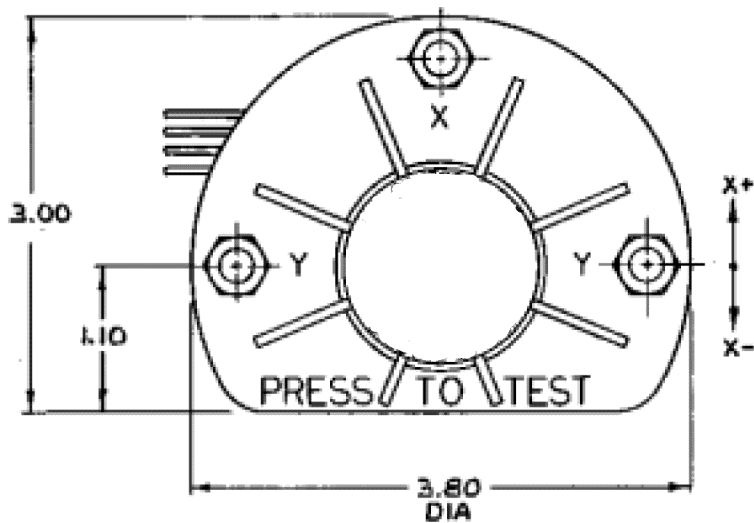

MOUNTING HOLE PATTERN IN BASE PLATE. STEEL PLATE ALSO SUITABLE FOR WELDING TO MACHINE.

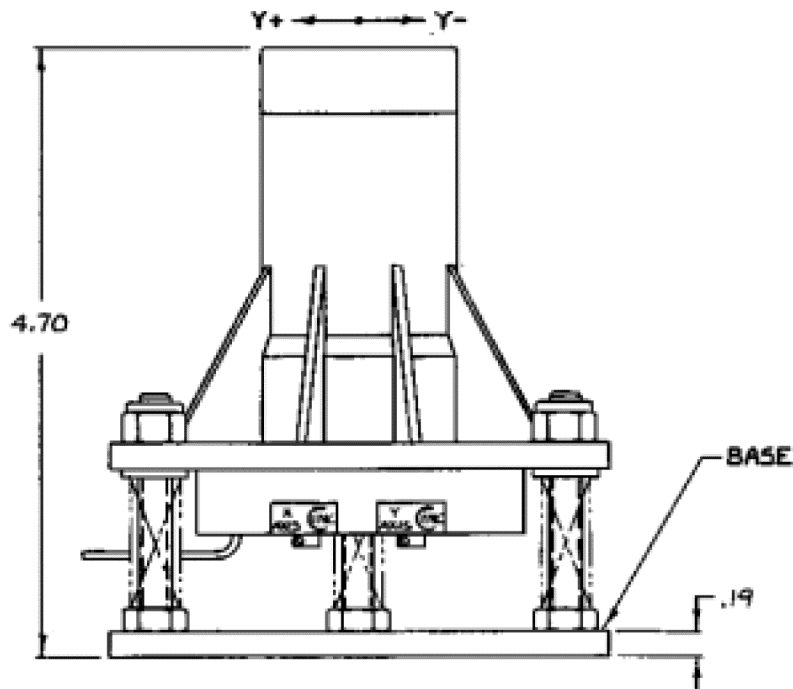

REV.	DESCRIPTION	DATE
A	GREEN WIRE WAS BROWN BLUE WIRE WAS GREEN	3-31-83 RAS
B	X OUTPUT WAS YELLOW Y OUTPUT WAS BLUE	6-13-83 RBS
C	ADDED 10% OUTPUT AT 6°	3-12-84 RAS
D	REMOVED VAEF OUTPUT	4-18-84 RAS

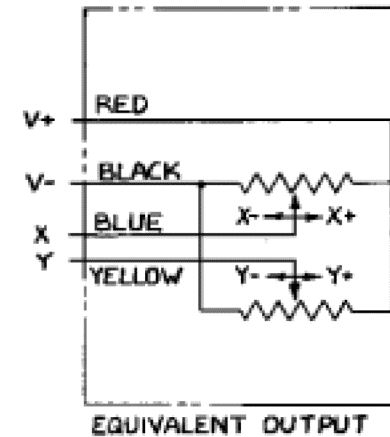

3) X & Y OUTPUTS ARE EQUAL TO 50% OF V+ AT LEVEL, 80% OF V+ AT +6° INCLINATION & 20% OF V+ AT -6° INCLINATION PROPORTIONAL WITH INCLINATION ANGLE.

2) MAXIMUM INCLINATION ANGLE IS 7°

NOTES: 1) V+ CAN BE 6 OR 12 VDC

		DRAWING NO.		REV.
		SIZE	SCALE	
MATERIAL SPEC.		DRAWING TITLE		
COND.		DI-AXIAL ANGLE SENSING TRANSDUCER		
SURF. TREAT.		MODEL 425 - 42		
DATE	DESIGNER	CHECK	PROJ. ENGR.	DATE
				2-28-83

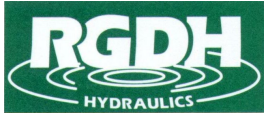

Level Sensor Part Numbering

Example: M400B-30-20TR Normally closed, sourcing, 3° trip angle, 2 sec time delay on reset with Bubble Level

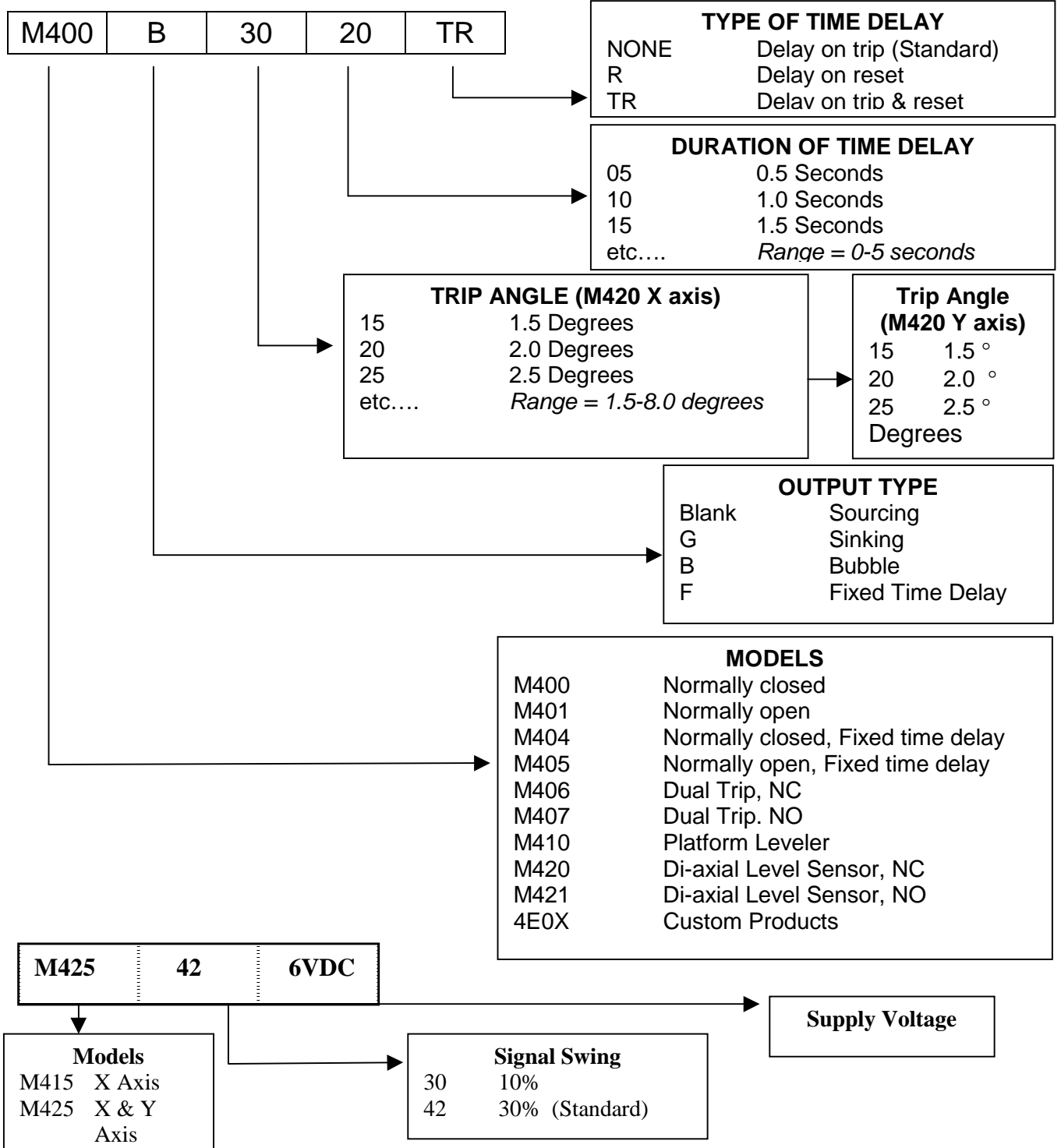

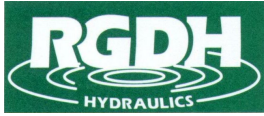

MODELS 415 AND 425 CALIBRATION PROCEDURE (10% SIGNAL SWING)

REFERENCE INSTALLATION DRAWING B-01948 OR DATA SHEET 114

All M415 and M425 angle sensors are calibrated level to the horizon at the time of shipping. If re-leveling is necessary, follow the steps below.

1. Mount the sensor to the machine by either bolting or tack welding the base plate to a horizontal surface.
2. Connect Red and Black power wires of the sensor to an appropriate power source. Power supply to the sensor is generally a P-Q M500 Series Valve Drive Board or M800 Angular Display.
NOTE: Check the part number labeled on the sensor for the proper supply voltage. Most sensors are 6VDC.
3. Provide voltage supply to P-Q valve drive board or M800 Angular Display or appropriate source.
NOTE: If connected to an M800 Angular Display, the display can be used to level the sensor.
4. Using a voltmeter, measure and record the voltage supply across the Red and Black wires of the sensor.
5. Connect voltmeter across the Blue wire and Black wire of sensor. This is the "X" axis output.
6. Adjust stud nuts until voltmeter readout equals (1/2) the voltage supply from step 4.
7. For M425 applications, connect voltmeter leads to the Yellow wire and the Black wire. This is the "Y" axis output.
8. Follow Step 6 for the Y axis.
9. Check the readout in the X axis once again and repeat Step 6 for both axes as necessary.
10. The Angle Sensor is now leveled to your application. With the voltmeter connected as in step 5 or step 7, proper signal swings for both X and Y axes will read:

Voltage Supply	Neutral (0°)	Full Tilt (+6°)	Full Tilt (-6°)
6VDC	3.0VDC (± .03)	3.6VDC (± .18)	2.4VDC (± .18)

* The 415/425 adjustable trimpots are factory set to 6°. Turning CCW will decrease the tilt angle required to reach full voltage signal.

M415/425 Angle Sensor with M800 Angular Display

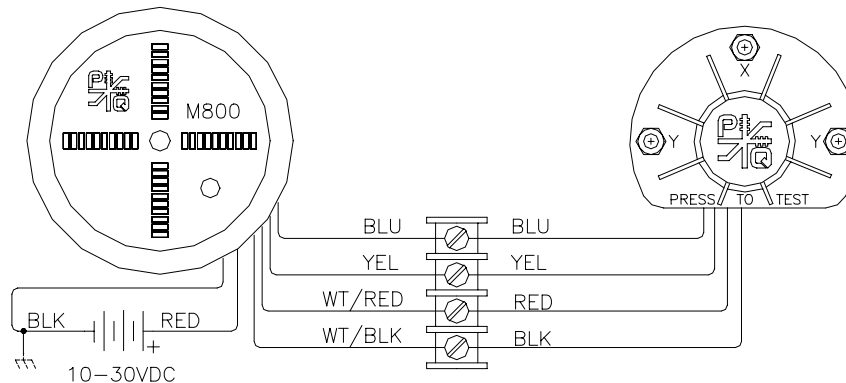



MODELS 415 AND 425 CALIBRATION PROCEDURE (30% SIGNAL SWING)

REFERENCE INSTALLATION DRAWING B-10976 OR DATA SHEET 114

All M415 and M425 angle sensors are calibrated level to the horizon at the time of shipping. If re-leveling is necessary, follow the steps below.

1. Mount the sensor to the machine by either bolting or tack welding the base plate to a horizontal surface.
2. Connect Red and Black power wires of the sensor to an appropriate power source. Power supply to the sensor is generally a P-Q M500 Series Valve Drive Board or M830 Angular Display.
NOTE: Check the part number labeled on the sensor for the proper supply voltage. Most sensors are 5V or 6V DC.
3. Provide voltage supply to P-Q valve drive board or M830 Angular Display or appropriate source.
NOTE: If connected to an M830 Angular Display, the display can be used to level the sensor.
4. Using a voltmeter, measure and record the voltage supply across the Red and Black wires of the sensor.
5. Connect voltmeter across the Blue wire and Black wire of sensor. This is the “X” axis output.
6. Adjust stud nuts until voltmeter readout equals (1/2) the voltage supply from step 4.
7. For M425 applications, connect voltmeter leads to the Yellow wire and the Black wire. This is the “Y” axis output.
8. Follow Step 6 for the Y axis.
9. Check the readout in the X axis once again and repeat Step 6 for both axes as necessary.
10. The Angle Sensor is now leveled to your application. With the voltmeter connected as in step 5 or step 7, proper signal swings for both X and Y axes will read:

Voltage Supply	Neutral (0°)	Full Tilt (+6°)	Full Tilt (-6°)
5VDC	2.5VDC (± .025)	4.0VDC (± .15)	1.0VDC (± .15)
6VDC	3.0VDC (± .03)	4.8VDC (± .18)	1.2VDC (± .18)

* The 415/425 adjustable trimpots are factory set to 6°. Turning CCW will decrease the tilt angle required to reach full voltage signal.

M415/425 Angle Sensor with M830 Angular Display

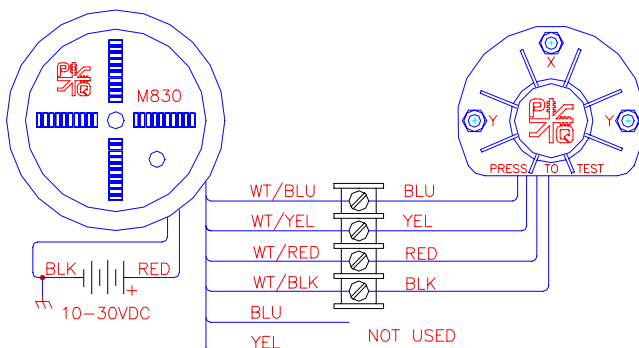

M425 Angle Sensor with Valve Drive Boards

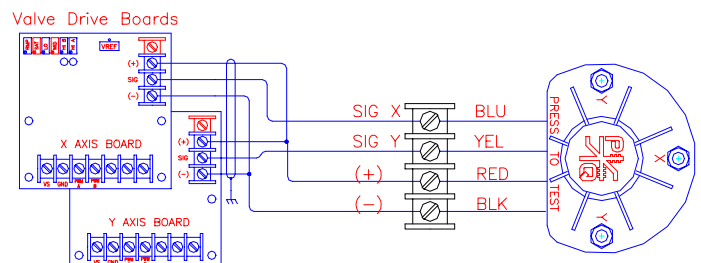

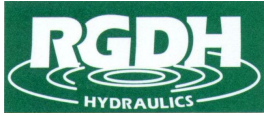

LEVEL SENSOR MOUNTING PATTERNS

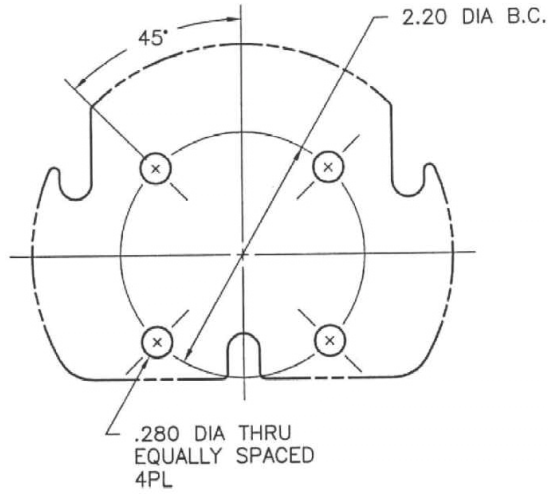

MOUNTING PATTERN
OPTION 1

ALSO SUITABLE FOR WELDING
TO MACHINE.

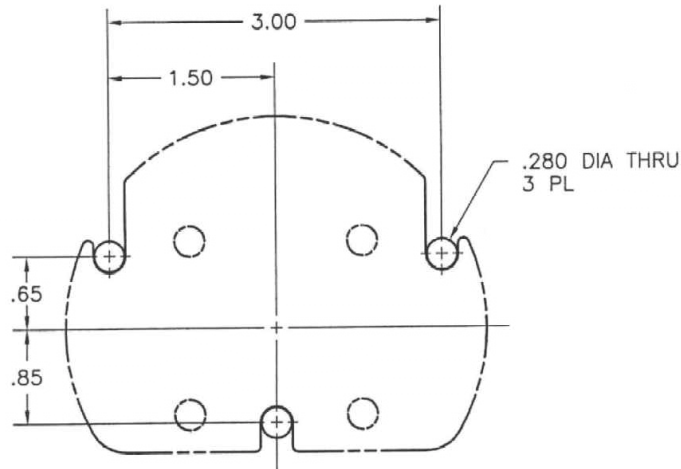

MOUNTING PATTERN
OPTION 2